

M-011 = Z_V R c D e R X V

Ultra-High-Precision, Side-Drive Linear Stages with Magnetic-Kinematic Bearings

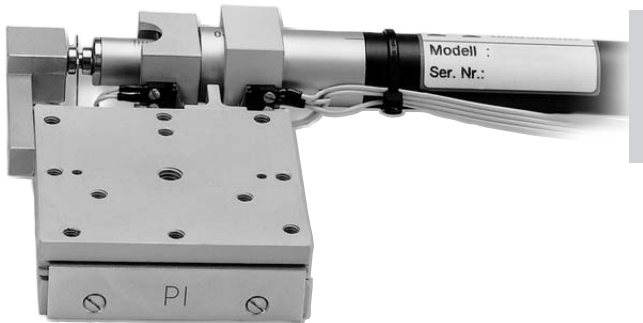

M-011.D01 translation stage

- Travel Range to 15 mm
- Compact Side Drive
- Straightness/Flatness $\leq 0.2 \mu\text{m}$
- PZT Drive for Scanning and Tracking Applications
- 0.1 μm Resolution with Closed-Loop DC Motor
- 5 nm Resolution with Closed-Loop PZT Drive

M-011 ultra-high-precision magnetically-coupled stages use the force of integrated magnets to preload the bearing. This magnetic preload results in extremely uniform and smooth motion with minimum friction. Unlike conventional stages, where two bearings with limited parallelism guide the carriage (inducing runout and rotational errors) in M-011 stages, only one of the two linear bearings has a guiding function (V-groove) while the second bearing is for support only (U-groove).

This design allows only on-axis forces (drive direction) to be transmitted to the stage; torque-induced positioning errors resulting from non-parallelism between the drive axis and the guiding axis are eliminated.

Six Different Versions

The basic version, the M-011.00, is equipped with a precision manual micrometer providing a sensitivity of 1 μm . M-011.D01 is equipped with a closed-loop DC-motor drive providing 0.1 μm minimum incremental motion.

High-Resolution Piezo Option

For both the manual and motorized version, closed-loop and open-loop piezo drives are available. They provide 5 nm minimum incremental motion over a travel range of 30 μm and allow for dynamic operation such as scanning and tracking. The closed-loop piezo drive provides repeatability of 60 nm (see the "Piezo Actua-

tors" section for further details on piezo actuators and recommended controllers). All stages can be cross stacked and combined with the M-052 Z-axis mounting bracket to provide multi-axis motion (vertical use of the M-011 only permitted with loads less than 0.1 kg, no extended Z-axis bracket for motorized Z-stage available).

Upgrades

M-011 stages without piezo drives or DC-motor drives can be upgraded at a later date (see ordering information).

Notes

See "Accessories", page 7-92 ff. for adapters, brackets, etc.

Ordering Information

- M-011.00**
Translation Stage, 15 mm
- M-011.P0**
Translation Stage, 15 mm, Manual + PZT Drive
- M-011.PS**
Translation Stage, 15 mm, Manual + Closed-Loop PZT Drive
- M-011.D01**
Translation Stage, 10 mm, DC-Motor Drive
- M-011.DP1**
Translation Stage, 10 mm, DC-Motor + PZT Drive
- M-011.DS1**
Translation Stage, 10 mm, DC-Motor + Closed-Loop PZT Drive

Upgrades

- M-011.U0** Upgrade Kit with Open-Loop PZT Drive
- M-011.US** Upgrade Kit with Closed-Loop PZT Drive
- M-011.UD** Upgrade Kit with DC-Motor Drive and Limit Switches (Factory Installed)

Ask about custom designs!

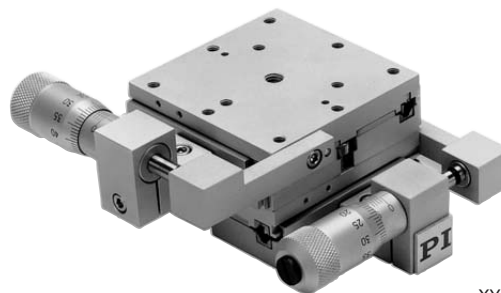

XY combination of two M-011.00 stages

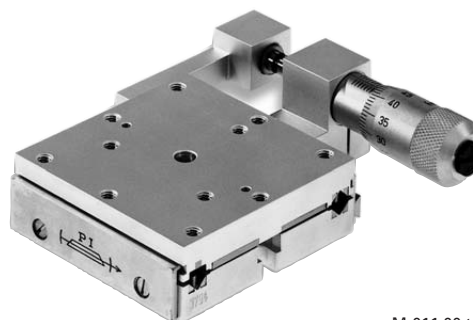

M-011.00 translation stage

Ultra-Straight Motion

The coupling between the stage and the space-saving side-drive units (DC-motor drives, PZTs, micrometer drives) is not rigid but via mag-

Application Examples

- Microscopy
- Quality control
- Metrology

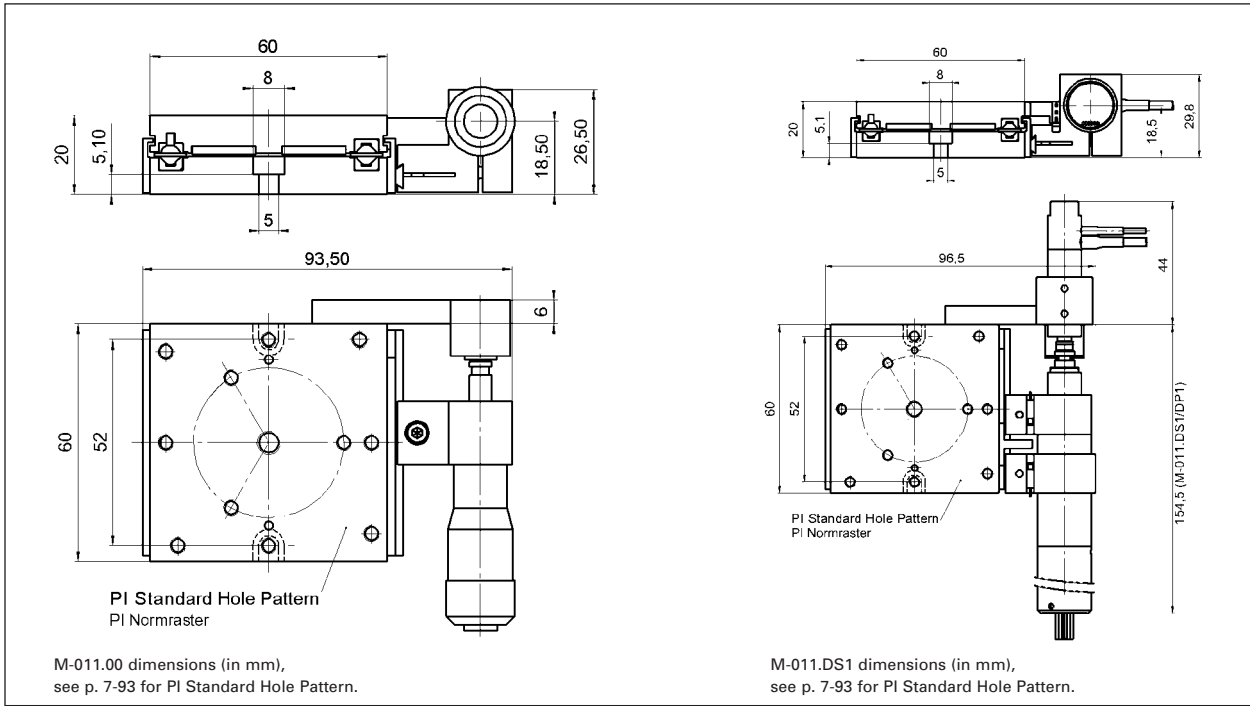

- Piezo Actuators
- Nanopositioning & Scanning Systems
- Active Optics / Steering Mirrors
- Tutorial: Piezo-electrics in Positioning
- Capacitive Position Sensors
- Piezo Drivers & Nanopositioning Controllers
- Hexapods / Micropositioning**
- Photonics Alignment Solutions
- Motion Controllers
- Ceramic Linear Motors & Stages
- Index

Technical Data

Models	M-011.00	M-011.P0	M-011.PS	M-011.D01	M-011.DP1	M-011.DS1	Units	Notes see page 7-106
Travel range	15	15	15	10	10	10	mm	
Piezo fine travel range	-	30	30	-	30	30	µm	
Min. incremental motion (piezo drive)	-	0.005	0.005	-	0.005	0.005	µm	A4
Repeatability (piezo drive)	-	-	0.06	-	-	0.06	µm	
Design resolution (DC Motor)	-	-	-	0.0035	0.0035	0.0035	µm	A3
Min. incremental motion	1	1	1	0.1	0.1	0.1	µm	A4
Unidirectional repeatability	-	-	-	0.1	0.1	0.1	µm	
Bidirectional repeatability	-	-	-	2	2	2	µm	
Backlash	-	-	-	2*	2*	2*	µm	
Straightness / flatness per 5 mm	0.1	0.1	0.1	0.1	0.1	0.1	µm	
Straightness / flatness full travel	0.2	0.2	0.2	0.2	0.2	0.2	µm	
Max. velocity (motor)	-	-	-	0.7	0.7	0.7	mm/sec	
Max. normal load capacity	1	1	1	1	1	1	kg	B1
Max. push/pull force	7 / 5	7 / 5	7 / 5	7 / 5	7 / 5	7 / 5	N	B2
Max. lateral force	5	5	5	5	5	5	N	
Drive	M-623	M-623	M-623	M-227.10	M-227.10	M-227.10		
Piezo drive	-	P-840.20	P-841.20	-	P-840.20	P-841.20		D1
Encoder resolution	-	-	-	2048	2048	2048	counts/rev.	
Drivescrew pitch	0.5	0.5	0.5	0.5	0.5	0.5	mm/rev.	
Gear ratio	-	-	-	69.12:1	69.12:1	69.12:1		
Nominal motor power	-	-	-	2	2	2	W	
Motor voltage	-	-	-	12	12	12	V	
Weight	0.35	0.4	0.42	0.55	0.6	0.62	kg	
Body material	Al, St	Al, St	Al, St	Al, St	Al, St	Al, St		L
Recommended piezo controller (codes explained see page 6-11)	-	A, C, G	D, H	-	A, C, G	D, H		
Recommended motor controller	-	-	-	C-843 C-848, C-862	C-843, C-848, C-862	C-843, C-848, C-862		D2

* gearhead